

Pressure Gauge Transmitter – MX series

CE  II 1/2GD c Ex ia IIC Ex iaD 20 T6/T5 T85°C/T100°C

Directive

ATEX 94/9/CE

CENELEC standards

EN 837-1: 1998	EN 60079-26: 2004
EN 837-2: 1998	EN 61241-0: 2004
EN 1127-1: 1997	prEN 61241-11: 2005
EN 60079-0: 2004	EN 13463-1: 1999
prEN 60079-11: 2006	EN 13463-5: 2000

IMPORTANT – READ CAREFULLY

Contents

- 1.1 Important information
- 1.2 Function
- 1.3 Application
- 1.4 Classification
- 1.5 Electrical characteristics
- 1.6 Electrical connection
- 1.7 Safety instructions
- 1.8 Special conditions for a safe use
- 1.9 Commissioning
- 1.10 Resetting and maintenance

1.1 Important information

Read this instruction manual carefully before installing and commissioning the unit. Keep it in a safe place, where it is accessible to users at any time.

The safety of any instrument results from the careful selection of the model and installation in the system, as well as from compliance with the maintenance procedures drawn up by the manufacturer.

The persons tasked with the selection, installation and maintenance must be able to recognise the conditions that have a negative impact on the instrument's ability to perform its function and which may lead to premature breakage or failure. Therefore, qualified, trained technicians are to be employed for carrying out the procedures laid down in the plant regulations.

Incorrect use may result in damage to the instrument, and possibly cause breakage or damage to personnel or the plant.

In order to correctly select the functional and constructive characteristics of the instruments, we recommend consulting the most up-to-date version of the catalogue data sheets, available on-line at the website <http://www.nuovafima.com>

The user is entirely responsible for ensuring correct installation and maintenance.

1.2 Function

The transmitter pressure gauge has a double function: it displays locally (pressure gauge) an input pressure value and it turns it into an output electrical signal 4 ... 20 mA (transmitter). The electrical signal changes proportionately to the input pressure.

1.3 Application

The MX series of pressure gauge transmitters are used for measuring the pressure of liquid and gas fluids, and are suitable for use in places in which there is a risk of explosion. Ambient and process temperatures must be within the limits stated on the tag.

1.4 Classification

II 1/2GD c Ex ia IIC Ex iaD 20	T6(85°C) @ Ta ≤ 60°C T5(100°C) @ Ta ≤ 80°C
---------------------------------------	---

1.5 Electrical characteristics

Power supply voltage	(8)10 ... 30 V
Output	4 ... 20 mA
Ui (maximum voltage):	30 Vdc
Ii (minimum current):	100 mA
Pi (maximum power):	1 W
Ci (equivalent internal capacity):	19 nF
Ci (equivalent internal capacity + permanent cable):	19 nF + 0,2 nF/m
Li (equivalent internal inductance):	~ 0
Li (equivalent internal inductance + permanent cable):	~ 0 + 2 μH/m

() For some configurations the minimum power supply voltage is 8 V.

1.6 Electrical connection

Wiring diagrams

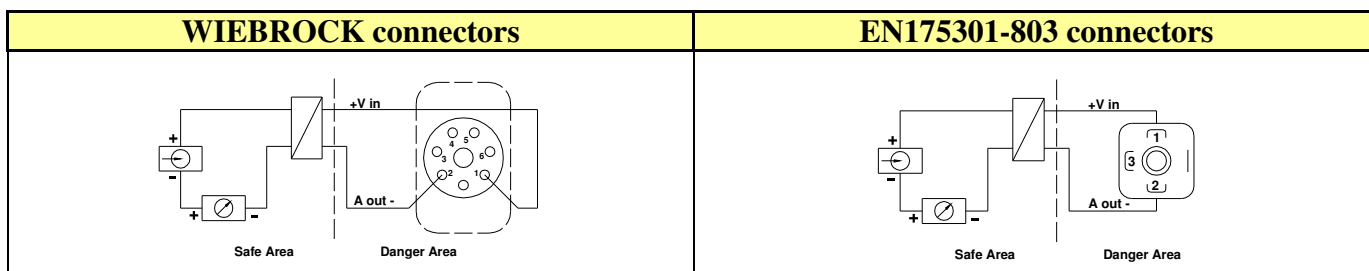

The transmitter's metal case must always be connected to the earth using the threaded connector for the process, in order to protect it against fluctuations due to electromagnetic fields and electrostatic charges. If this cannot be done, connect the transmitter to earth using the connector and the shield on the cable.

1.7 Safety instructions

The transmitter must be connected to an Associated piece of Equipment (Diode safety barrier or Galvanic insulator) with an [Ex ia] or [Ex ib] execution, complying with the maximum voltage (Ui), current (Ii), and power (Pi), and taking into consideration the internal capacity (Ci) and inductance (Li) values, indicated in the "Nominal Characteristics". If the barrier has an "ib" protection level, the entire system should be at an "ib" level suitable only for not inflammable fluids.

The transmitters must be installed in compliance with the European Standard EN 60079-14 (current edition) and maintenance operations must be carried out according to the requirements of the European standard EN 60079-17 (current edition); Every Intrinsic Safety transmitter must be included in the *Document Describing the System* (EN 60079-14 and EN 60079-25).

1.8 Special conditions for a safe use

In case of use with gaseous fluids, the MX transmitter pressure gauges should not receive pulsations with fast and repeated change of pressure. In case of pulsations with a pressure variation up to 80% of the scale range with a frequency higher than one pulsation per minute and with a rise time less than 1", it is necessary to install filters, mechanical choking systems or much better diaphragm seals in order to prevent the direct contact between the transmitter pressure gauge and the process fluid.

1.9 Commissioning

Before an electrical safety structure is commissioned within a plant or a system, the user must check that it complies with the design data and is installed correctly.

Check that the Associated Equipment called for in the relevant *Document Describing the System* is connected to each transmitter.

Tighten the threaded portion of the transmitter, applying a torque (max 50 Nm) using a suitable spanner on the hexagonal part of the process connector, without applying force to the casing with your hands or pipe wrench.

Remove the connector as shown in figure 1 and connect the cable as shown in figure 2.

Refit the connector, complete with all its gaskets, to guarantee the declared IP protection level, and fix it to the transmitter.

The IP protection according to EN 60529-1:1992 is assured only if the female connector, complete with the cable connexion, is assembled to the instrument and all the components are assembled correctly.

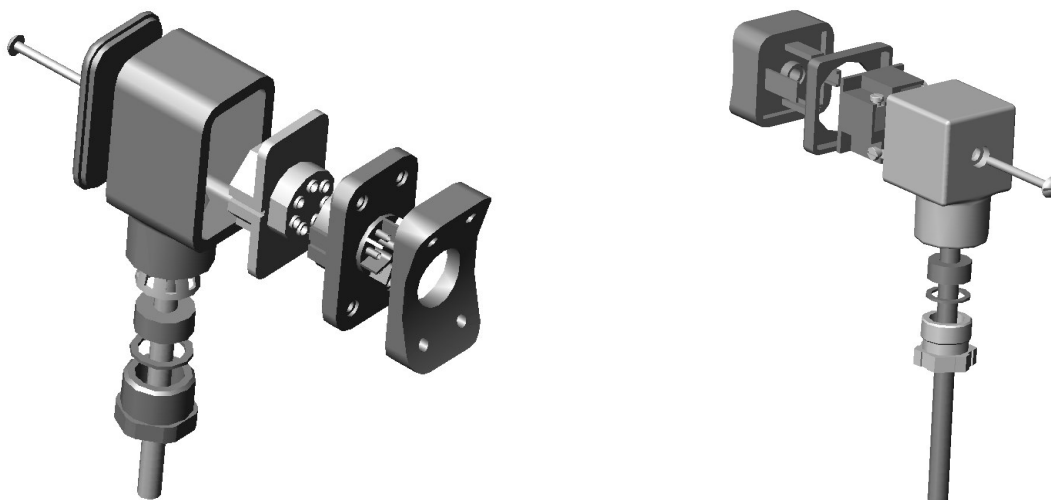

Figure 1 – Exploded view of the connectors

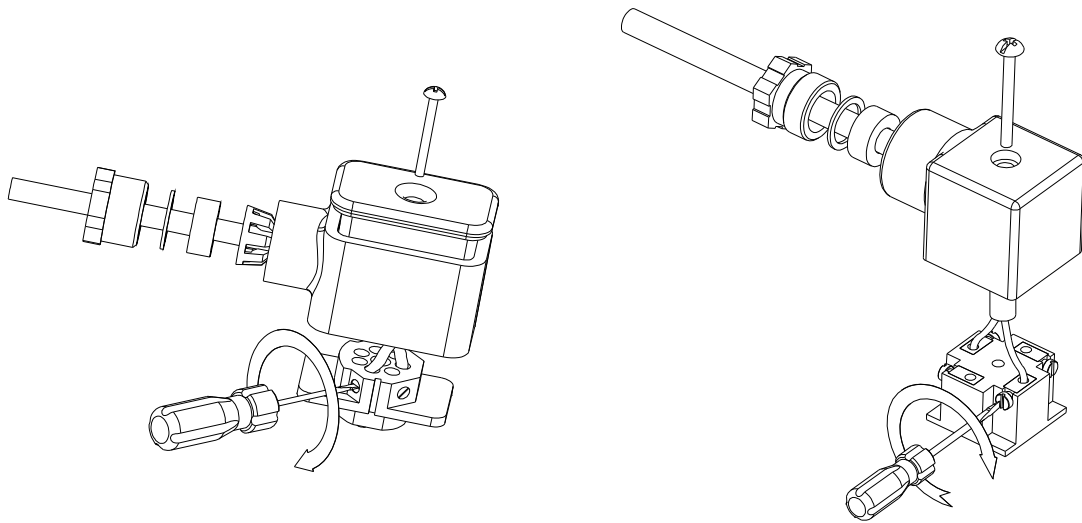

Figure 2 – Connecting the wires

1.10 Resetting and maintenance

For the versions available, the zero and the scale span can be adjusted as follows:

- Remove the plug from the upper side of the transmitter pressure gauge
- Setting the zero (Z)
- Setting the span (S)

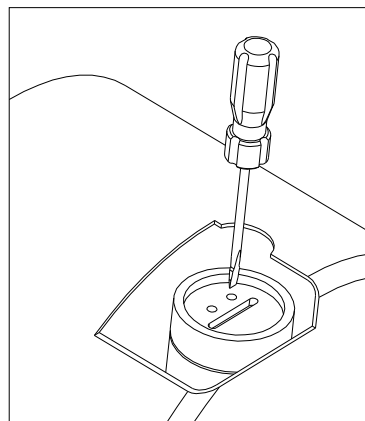

Figure 3 - Setting

Maintenance operations are to be entrusted to duly qualified personnel that are trained on the specific characteristics of the equipment and the Intrinsic safety technique, and they are to comply fully with the provisions of the EN 60079-17 European standard (current edition).

The MX series of transmitters is “*maintenance free*”. The resetting cycle depends on the application they are used for.

Suggested setting frequency: 1 year.

If a fault occurs, contact NUOVA FIMA S.p.A.

Using transmitters that have been subjected to work not explicitly authorised by NUOVA FIMA S.p.A. relieves the Company of any and all responsibility and causes the contractual guarantee to become null and void.